

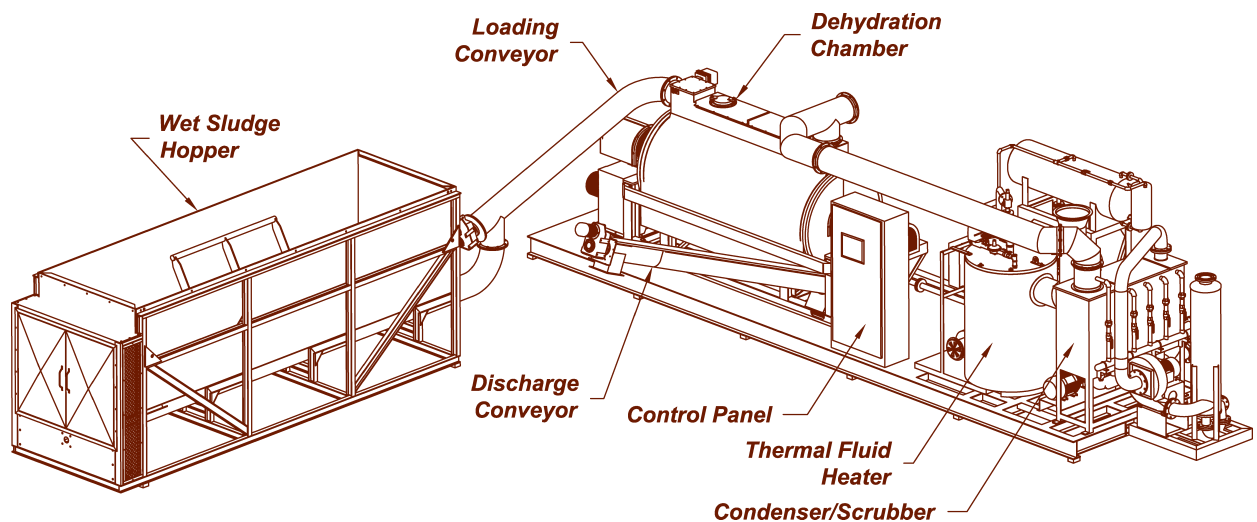

FENTON FENIX™ CM DRYERS The Complete Solids Solution



The Fenix™ uses indirect thermal heating to dehydrate wastewater sludge, economically producing Class A Exceptional Quality* (EQ) biosolids. The Fenix™ Continuous Mix system includes an integrated drying unit, a wet sludge hopper, wet sludge in-feed auger, and dried biosolids discharge auger. For systems that bundle dewatering and other technologies, see Fenton's DD and TDP technical sheets.



The illustration above shows the standard design of the automated CM system. For a process illustration, see the Fenix Technical Information Overview sheet or visit ifenton.com.

How it Works

Dewatered sludge enters the hopper then moves to the dehydration chamber where a hollow-disk rotor turns the sludge. Heat to evaporate sludge moisture is produced by thermal fluid that is circulated through hollow rotor disks and the chamber jacket. Process steam exits via an enclosed air handling system that cools and separates air from moisture and particulates. Once a batch of biosolids has dried to the desired level, it exits the machine via a discharge auger.

Biosolids Performance

- Typical solids weight reduction of 80%
- Typical volume reduction of 75%
- Total fuel usage of 1,400-1,557 btu's per pound of water
- Can run on natural gas, #2 fuel oil, propane, digester gas, or landfill gas

Operational Flexibility

- Run on shift schedule or continuously
- Auto-adjusts to variable sludge cake
- Auto-adjusts to produce biosolids with desired dehydration level
- Large hopper holds 5-8 loads of sludge

* Input sludge that exceeds heavy metal content limits set by the EPA will not qualify as EQ biosolids.



Dryer Models

The **Fenix™** CM line has four dryer size options to meet different capacity needs. This makes the **Fenix™** an affordable solution for plants serving populations as small as 4,000 or as large as 100,000 – and plants can add more of these modular units for larger populations. The chart below shows information on dryer model capacities and resource usage. Visit ifenton.com to view a sizing chart based on runtimes.

	Fenix™ CM 8/2	Fenix™ CM 24/5	Fenix™ CM 48/10	Fenix™ CM 72/14
Apx. Sludge Processing Capability*	8 WTD	24 WTD	48 WTD	72 WTD
Apx. Resulting Biosolids Generation*	2 DTD	5 DTD	10 DTD	14 DTD
Capacity per Load of Sludge	1.25 cubic yards	3.33 cubic yards	9.5 cubic yards	13.7 cubic yards
Wet Sludge Hopper Capacity	8 cubic yards	28 cubic yards	50 cubic yards	75 cubic yards
Maximum Fuel Usage Per Hour	2 MM BTU	5 MM BTU	8.5 MM BTU	12.25 MM BTU
Total Horsepower/Electrical Service†	32 HP/80 amp	60 HP/100 amp	118 HP/200 amp	166 HP/250 amp
Usage of Non-Potable Plant Water	40 GPM	80 GPM	140 GPM	220 GPM

* Assuming input sludge with 14-16% solids
 † Factual electrical usage apx. 60-65% FLA

Easy System Placement

The skid-mounted **Fenix™** CM dryers can be placed indoors or outdoors (under covering) and have four basic configurations (shown below). With pre-piped and pre-wired system integration, the **Fenix™** has a single connection point for utility lines plus one exhaust flue, a recycled water supply line, and a water drain line.



Fenix™ Model	Dryer Skid Dimensions L x W x H			Hopper Dimensions L x W x H			Auger Lengths	
	A	B	Height	C	D	Height	E	F
CM 8/2	29'-0"	8'-6"	9'-6"	9'-6"	5'-8"	8'-10"	7'-2" to 12'-8"	7'-7"
CM 24/5	34'-0"	8'-6"	12'-7"	23'-0"	5'-8"	8'-6"	8'-4" to 11'-4"	11'-5"
CM 48/10*	35'-0"	8'-6"	12'-7"	23'-0"	8'-6"	11'-6"	14'-1" to 19'-11"	8'-7"
CM 72/14*	40'-0"	8'-6"	14'-7"	23'-0"	12'-6"	11'-6"	18'-9" to 23'-4"	8'-7"

*The thermal unit is separated from the main skid. Dimensions: 12'-7"L x 6'-0"W x 14'x4"H

4306 HWY 377 SOUTH
 BROWNWOOD, TX 76801
 PHONE: (800) 521-1708
 FAX: (325) 646-7027
 SALES@IFENTON.COM
 IFENTON.COM

For additional technical information and project pricing contact Fenton at (800) 521-1708 or sales@ifenton.com. To learn more about the ease, affordability and reliability of the Fenton Fenix™ visit ifenton.com.