

# INTRODUCING

## ROOTS® IntelliView® Aeration and Blower Control Systems

**It's All About  
Saving Energy!**

**DRESSER®**

**Roots**

# ROOTS® IntelliView® Control Systems

## Frequently Asked Questions

---

### **Q) What are ROOTS® IntelliView® Controls?**

A) ROOTS® IntelliView® Controls are an *integrated system of specialized control* products developed specifically to address the needs of blower and aeration controls. The basic building block is a family of pre-engineered special purpose controllers. Additional sensors, operators, and control products are added as needed to create a fully operational control system engineered and supported by Dresser Roots.

### **Q) What is included in a typical IntelliView® system?**

A) The complete IntelliView® system usually consists of individual controllers for each blower with a master controller to integrate the individual process control and blower control panels. Other specialized controllers are provided to meet specific process needs, such as controlling a group of aeration tanks to maintain dissolved oxygen concentration. Most IntelliView® systems also include sensors and control devices. These systems can include air flow transmitters, bearing vibration and temperature sensors, analytic instruments, control valves, and VFDs – virtually any blower or process control device. IntelliView® controllers can be shipped loose, provided with local control panels engineered and assembled by Dresser Roots, or installed in motor starter or VFD enclosures provided by Dresser Roots. Dresser Roots can take total process control responsibility.

### **Q) Can I connect IntelliView® controls to my existing SCADA and PLC networks?**

A) Yes. IntelliView® controls come with a number of serial and Ethernet communications capabilities built in. In addition a variety of external communication bridges are available. That means that IntelliView® controls can communicate on most communication networks.

### **Q) How are IntelliView® controllers different from a PLC?**

A) PLCs (Programmable Logic Controllers) are general purpose control devices. The IntelliView® system was engineered by Dresser Roots specifically for blower and aeration control. This system employs Dresser Roots' proven control logic and algorithms, while PLCs are generally custom programmed for each project and application. HMI (Human Machine Interface) requires separate hardware and programming with PLC systems but the IntelliView® controller integrates HMI and control in a single integrated device.

### **Q) Is service available for IntelliView® controls after installation?**

A) Dresser Roots worldwide service organization is available to provide repairs, parts, and maintenance. With 150 years of manufacturing experience, you can have confidence in the availability of long-term product support and maintenance. Dresser Roots' process specialists are available for commissioning the more complex or specialized process control systems.

**Q) Why shouldn't I have my system integrator create the controls for my blowers and aeration system?**

A) System integrators and panel shops may not fully understand the operation of blowers and the process constraints of aeration systems. That means the facility's design engineer may have to take responsibility for the details of the system design and control strategies. At commissioning every control loop must be field tested to verify that actual performance meets the process needs. On the other hand, IntelliView® controls were developed by Roots' experts in blowers and in aeration control. These controls include proven, specialized control algorithms developed through years of experience. A wide variety of blower health monitoring and process control requirements are built into IntelliView® controls. A simple setup procedure is all that is required to implement the required control functions.

**Q) Are IntelliView® controls available in more than one model?**

A) Yes. IntelliView® controls come in several models:

- IntelliView® Basic for constant speed PD blowers and hardwired integral I/O
- IntelliView® Advanced for variable speed blowers with hardwired remote and integral I/O and communications control for VFDs
- IntelliView® M for multi-stage centrifugal blowers
- IntelliView® SS for single stage centrifugal blowers
- IntelliView® Master for process control of aeration systems and coordination of multiple blowers

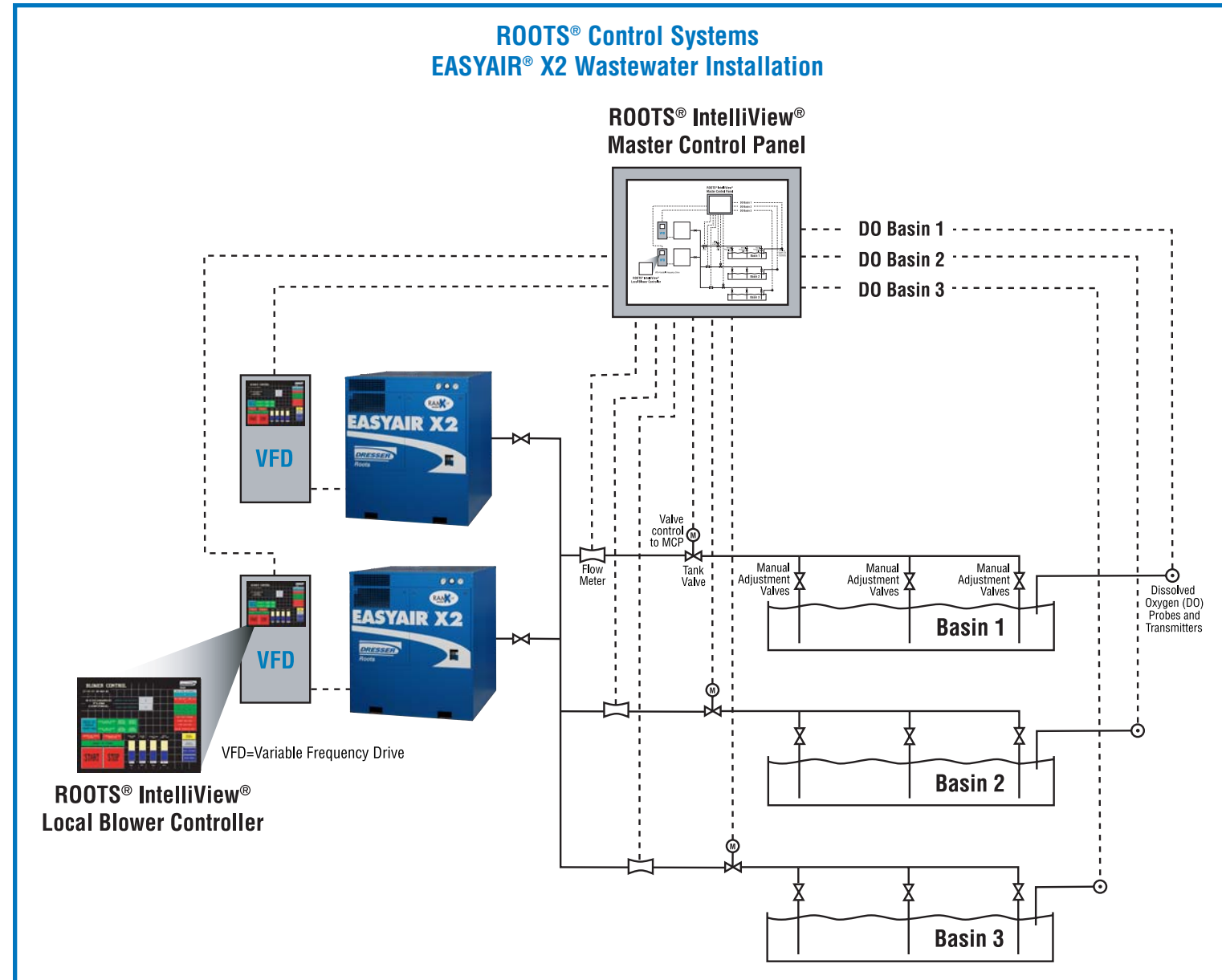

**Q) Are IntelliView® controllers available as components?**

A) IntelliView® Basic controllers can be made available to system integrators as components for inclusion in control panels, motor control centers, and control systems provided by others.

**Q) Can IntelliView® controllers be provided with blower packages?**

A) Yes – IntelliView® controllers can be included with EASYAIR® packages and other blower packages. These packages can also include motor controls VFDs sensors, and control valves. Roots can provide a complete sole source package.

**Q) What kinds of blower controls and protection are available with IntelliView® controls?**

A) An IntelliView® model is available for controlling virtually any type of blower. This includes positive displacement (constant and variable speed), multi-stage centrifugal (inlet throttled and variable speed), and single stage centrifugal (inlet guide vane, discharge diffuser vane, and dual vane control). Machine health monitoring functions include bearing temperature and vibration, inlet suction, discharge pressure, surge, overload, and inlet and discharge air temperature. Standard control capabilities include maintaining set air flow and pressure and Local/Remote control.

**Q) Do IntelliView® controls include overall process control as well as individual blower controls?**

A) Absolutely! Standard process control logic includes header pressure control, total system flow control (constant or scheduled), aeration system DO control, and aeration tank flow control with MOV (Most Open Valve) logic. The IntelliView® master controller provides overall process control and coordinates operation of individual blower controllers and basin controllers into an integrated control strategy.

**Q) My process has special control requirements. Can I still use IntelliView® controls?**

A) Yes. Because of the flexible system architecture and wide variety of standard control strategies most specialized requirements can be met by having Dresser Roots' application specialists assist you in selecting a system using a combination of standard controllers with appropriate standard control logic. If standard controllers are not the optimum choice for your installation, custom programming and expansion I/O (Input/Output) are available from Roots at a reasonable cost to satisfy almost any process control need.



**Roots**

**[www.rootsblower.com](http://www.rootsblower.com)**

Visit "Contact Us" page for your nearest location

**Houston, Texas Headquarters**

U.S. Toll Free Phone: 1-877-363-ROOT(S) (7668) • Direct Phone: 832-590-2600

**Connersville, Indiana Operations**

U.S. Toll Free Phone: 1-877-442-7910 • Direct Phone: 765-827-9285

**United Kingdom Sales and Factory Service** • Phone: +44 (0) 1695 52600

**USA/Canada Sales** • Phone: 773-444-3360

**Houston, Texas Factory Service** • Phone: 713-896-4810

**Mexico City Sales and Factory Service** • Phone: +52 55 5889 5811

**Dubai Sales and Factory Service** • Phone: +971 4-8830831

**Malaysia Sales** • Phone: +60 3 2163 0480

**China Sales** • Phone: +86 10 8486 2440

**Shanghai Factory Service** • Phone: +86 21 5858 7638

TSF-IntelliView rev.1007

©2007 Dresser, Inc. all rights reserved. • Printed in the U.S.A. • All information subject to change without notice. • ROOTS, IntelliView, and EASYAIR are registered trademarks of Dresser, Inc.