

# Ceramic Disc

Fine Bubble Aeration Systems

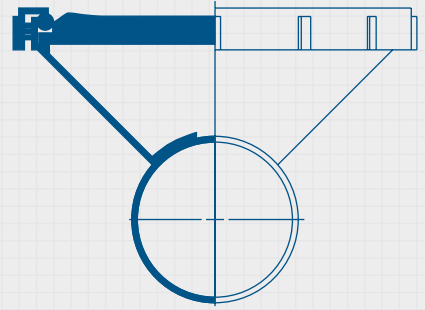

Sanitaire



**ITT Industries**  
*Engineered for life*

# Ceramic Disc

## Fine Bubble Aeration Systems

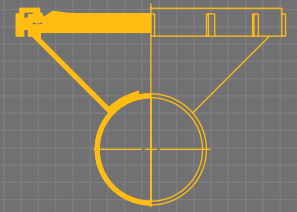

## Technology You Can Count On

**SANITAIRE® is the trade name recognized** throughout the wastewater treatment industry for quality products and advanced technology. Sanitaire fine bubble ceramic disc aeration systems incorporate superior and advanced engineering features in the ceramic element, the diffuser sealing method and the piping system joints and supports. The premier line of SANITAIRE fine bubble ceramic disc diffusers is considered the most efficient technology available for oxygen transfer in wastewater treatment applications.

### Owners and engineers prefer SANITAIRE fine bubble diffusers because:

- Power costs can be reduced by 50% or more.
- High oxygen transfer efficiency and low system headloss lead to low energy costs.
- The diffuser performance is restorable. They can be cleaned in-situ using the SANITAIRE In-Place Gas Cleaning System.

Sanitaire's leadership and experience in aeration technology has resulted in high quality SANITAIRE fine bubble disc aeration systems being specified more than any other. The ceramic disc fine bubble aeration system offers advantages in performance, ease of maintenance, construction integrity and quality. Ongoing research and development shows Sanitaire's commitment to the most technologically advanced diffused aeration system.

## Diffuser and Holder Features

- Unique contoured ceramic disc diffuser element design promotes dependable, uniform air distribution and bubble release.
- Top sealing, threaded retainer ring and holder design ensures airtight seal. As air pressure is increased, so is the sealing force on the O-ring gasket, thereby eliminating leaks.
- Diffuser holders are factory solvent welded to the air distribution piping providing superior mechanical strength and eliminating the necessity for field installation and leveling of individual assemblies.
- Ceramic disc diffusers are available in 9-inch (229-mm) or 7-inch (178-mm) diameters.

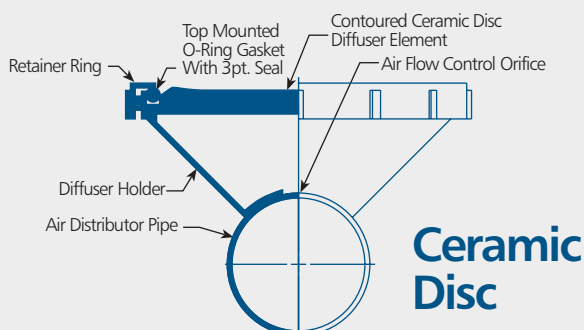

Top centerline diffuser mounting prevents cantilever or torque forces from being transmitted to piping system.





## Ceramic Disc Diffuser Advantages

- Superior quality PVC air distribution piping systems, time-proven over 25 years.
- High oxygen transfer efficiency and low system headloss.
- Service life exceeding 20 years.
- Quiescent surface pattern reduces freezing and airborne aerosol problems.
- Gentle mixing promotes excellent floc formation, preventing floc shear.
- All components made from corrosion resistant materials, PVC and stainless steel.
- Ease of installation – up to 12 units installed per man-hour, step-by-step O&M manuals, educational videos and field service/start up training provided with every system. Factory installed diffuser holders and pipe end fittings for reduced installation time.
- Existing aeration tanks can be easily upgraded with ceramic grid aeration, increasing the existing plant's organic capacity without adding tankage.
- Convenient shipping – diffusers, supports and piping are delivered in a compact palletized arrangement. Install or retrofit your existing system today with field proven, time-tested and cost-saving SANITAIRE fine bubble ceramic disc diffusers.
- Pressure monitoring and gas cleaning systems available.

## Quality Control

**Sanitaire has instituted** the most comprehensive quality control program in the industry. The quality control program ensures permeability, uniformity, strength and dimensional properties of the ceramic diffuser, as well as dimensional and material testing of the PVC piping and diffuser mounting system. These steps provide the customer with the assurance of receiving the highest quality and most energy efficient aeration system in the industry.

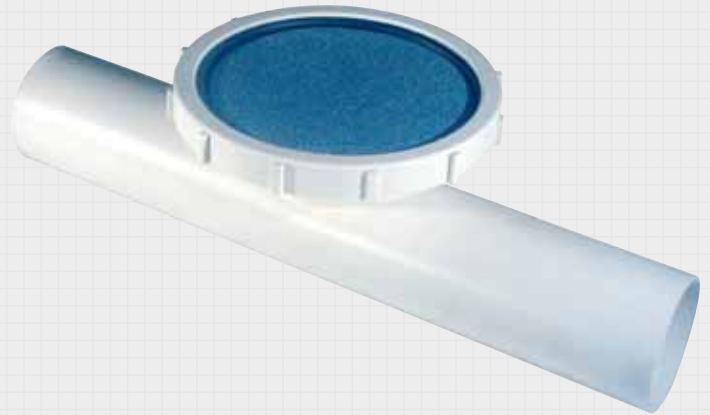

## Applications

- Aeration tanks
- Channel Aeration
- Post Aeration tanks

**Those who choose ceramic disc aeration...** get the best of all worlds when they choose proven Sanitaire systems for their wastewater treatment needs. Sanitaire provides time-tested aeration technology and products for municipal and industrial markets worldwide.

### Contact Sanitaire - the aeration leader for more information

9333 N. 49th Street  
Brown Deer, WI 53223 USA  
Tel 414 365 2200  
Fax 414 365 2210  
www.sanitaire.com

Sanitaire



**ITT Industries**  
*Engineered for life*